

# Maxim



**STOSA**  
CUCINE

# STOSA

## UNA FAMIGLIA ITALIANA. 50 ANNI DI STORIA E UNA SOLA GRANDE PASSIONE: LA CUCINA.

DA 50 ANNI PRODUCIAMO SOLO CUCINE, CREATE E PRODOTTE PER MIGLIORARE LA VITA DI CHI, OGNI GIORNO, VIVE NELLO SPAZIO PIÙ CONVIVIALE DELLA CASA. PROGETTIAMO E REALIZZAMO ESCLUSIVAMENTE IN ITALIA PRODOTTI ECCELLENTI NELLA QUALITÀ, REALMENTE SOSTENIBILI PER OGNI FAMIGLIA ITALIANA E PER I GIOVANI. ECCO PERCHÉ UNA CUCINA STOSA NASCE DA VALORI AUTENTICI COME IMPEGNO, ONESTÀ, RISPETTO E ORIGINALITÀ. IN ITALIA E IN OLTRE 40 PAESI NEL MONDO, CON UN MERCATO IN COSTANTE ESPANSIONE. IMPEGNO PER DARE IL MEGLIO DI NOI ATTRAVERSO OGNI SINGOLA CUCINA, DIRETTAMENTE A CASA TUA. ONESTÀ PER TRASFORMARE I NOSTRI PROGETTI IN SPAZI DI VITA DAVVERO SOSTENIBILI. RISPETTO PER LA NATURA CHE CI CIRCONDA E PER TUTTA LA FILIERA PRODUTTIVA. ORIGINALITÀ PER ESSERE SEMPRE PIÙ COMPETITIVI NELL'INNOVAZIONE TECNOLOGICA E FUNZIONALE. È COSÌ CHE OGNI GIORNO COSTRUIAMO LE NOSTRE CUCINE. PENSANDO A TE.

**STOSA, AN ITALIAN FAMILY. 50 YEARS OF HISTORY AND ONE GREAT PASSION: KITCHENS.**

FOR 50 YEARS WE'VE BEEN PRODUCING ONLY KITCHENS, DESIGNED AND BUILT FOR THOSE WHO ENJOY SPENDING TIME IN THE MOST WELCOMING ROOM IN THE HOME. OUR PRODUCTS, DESIGNED AND MADE ENTIRELY IN ITALY, STAND OUT FOR THEIR QUALITY YET ARE AFFORDABLE FOR ITALIAN FAMILIES AND YOUNG PEOPLE. BECAUSE A STOSA KITCHEN IS BASED ON AUTHENTIC VALUES LIKE COMMITMENT, HONESTY, RESPECT AND ORIGINALITY - IN ITALY AND A FURTHER 40 COUNTRIES WORLDWIDE, WITH A CONSTANTLY GROWING MARKET. COMMITMENT TO OFFER OUR BEST IN EVERY SINGLE KITCHEN, DIRECTLY IN YOUR OWN HOME. HONESTY TO TURN OUR DESIGNS INTO TRULY SUSTAINABLE LIVING AREAS. RESPECT FOR THE NATURE SURROUNDING US AND FOR THE WHOLE PRODUCTION CHAIN. ORIGINALITY TO BE MORE AND MORE COMPETITIVE WITH REGARDS TECHNOLOGICAL AND PRACTICAL INNOVATION. THAT'S HOW WE BUILD OUR KITCHENS EVERY DAY. THINKING OF YOU.

Maxim  
Simple and Chic



CONTEMPORANEA TANTO NELLE FORME QUANTO NELLA FUNZIONALITÀ, MAXIM GIOCA CON GLI SPAZI E I VOLUMI PER CREARE SOLUZIONI COMPATTE, DETERMINATE, E ALLO STESSO TEMPO APERTE, ACCOGLIENTI, LUMINOSE. UNA CUCINA MODERNA IN GRADO DI CONIUGARE PRATICITÀ E RESISTENZA, SEMPLICITÀ ED ELEGANZA.

CONTEMPORARY SHAPE, BUT CONTEMPORARY FUNCTIONS TOO. MAXIM PLAYS ON SPACES AND VOLUMES TO CREATE COMPACT SOLUTIONS THAT ARE FIXED YET OPEN, WELCOMING AND BRIGHT. A MODERN KITCHEN, CAPABLE OF BRINGING TOGETHER PRACTICALITY AND STURDINESS, SIMPLICITY AND ELEGANCE.





# Maxim

LA CUCINA CHE TI OFFRE  
MOLTISSIME POSSIBILITÀ  
DI SCELTA.

ANTA CON O SENZA MANIGLIA,  
SORPRENDENTI FINITURE  
DA ABBINARE PER OTTENERE  
LA MASSIMA PERSONALIZZAZIONE

MAXIM, THE KITCHEN THAT OFFERS  
A PLETHORA OF CHOICES.  
DOORS WITH OR WITHOUT HANDLES.  
SURPRISING MIX-AND-MATCH FINISHES  
FOR TOTAL PERSONALISATION.



## Maxim GOLA

PAG 4

PRESA MANIGLIA /  
HANDLE SOCKET

BRILL

BIANCO

PIOMBO

CORDA



## Maxim MANTIGLIA

PAG 36

MANIGLIE /  
HANDLES

STOSA CUCINE TI OFFRE  
UNA VASTA SERIE DI MANIGLIE  
DA ABBINARE ALL'ANTA DEL MODELLO MAXIM:  
CROMATE, SATINATE E COLORATE,  
DALLA FORMA LINEARE O ARCUATA,  
SCEGLI TU QUELLA PIÙ ADATTA  
ALLO STILE CHE VUOI DARE ALLA TUA CUCINA.

STOSA CUCINE OFFERS YOU A WIDE RANGE OF  
HANDLES FOR THE MAXIM DOOR: CHROME-PLATED,  
SATIN-FINISH, COLOURED, LINEAR OR ARCHED ...  
CHOOSE THE ONE THAT BEST SUITS THE STYLE  
YOU WANT FOR YOUR KITCHEN.

# Maxim 1

GOLA BIANCA n.1

UNA SOLUZIONE NATA PER OTTIMIZZARE AL MASSIMO LO SPAZIO E CREARE UN AMBIENTE RACCOLTO E ACCOGLIENTE, IN CUI È PROTAGONISTA IL DIALOGO TRA LA ZONA FUOCHI E L'ISOLA CENTRALE FORMATA DA BANCONE E TAVOLO DINING. I PENSIERI A VISTA ASSECONDANO L'IDEA DI UNO SPAZIO INFORMALE, DANDO VITA A UNA CUCINA CHE TRASMETTE CALORE E VIVACITÀ.

A SOLUTION CONCEIVED TO OPTIMIZE THE SPACE TO THE MAXIMUM AND CREATE A WELCOMING ENVIRONMENT THAT GELS, PUTTING DIALOGUE IN THE CENTRE, BETWEEN THE FIRE AREA AND THE CENTRAL ISLAND FORMED BY THE COUNTER AND DINING TABLE. THE OPEN WALL UNITS FOLLOW THE IDEA OF AN INFORMAL SPACE, BREATHING LIFE INTO A KITCHEN THAT TRANSMITS WARMTH AND VIVACITY.



# Maxim n.1

L'ACCOSTAMENTO DI COLORI TENUI COME IL BIANCO FIANDRA E IL SETA DANNO ALL'AMBIENTE UN FEELING RILASSANTE E OSPITALE.

THE COMBINATION OF LIGHT COLOURS LIKE DAMASK LINEN WHITE AND SILK GIVES THE ENVIRONMENT A RELAXING AND HOSPITABLE FEEL.



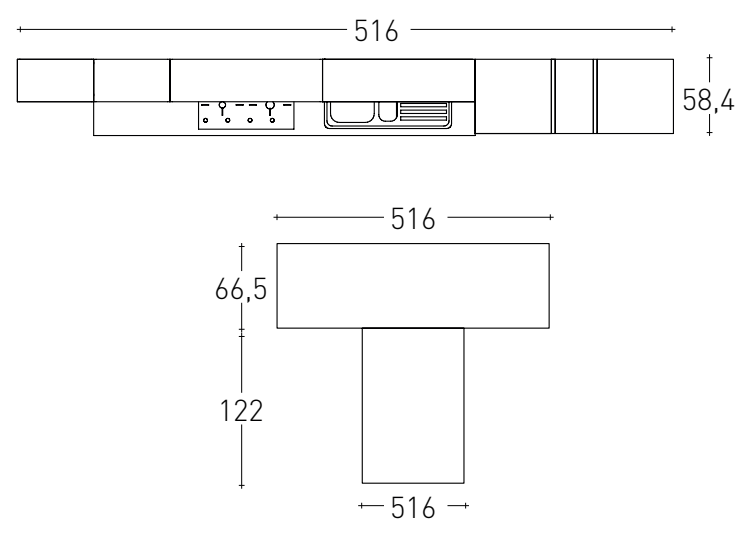

FRASSINO SETA

FRASSINO BIANCO FIANDRA

TOP  
MARMO SPESS. 3 CM  
COLORE KAESER BROWN

L'APERTURA DELLE ANTE AVVIENE CON IL SISTEMA GOLA SCAVATA, ESSENZIALE E MINIMALE, E LO SCHIENALE IN VETRO LUMINOSO CON ACCESSORI MAGNETICI DONANO ALLA CUCINA UN LOOK ELEGANTE E MODERNO.

THE OPENING OF THE DOORS TAKES PLACE WITH A HOLLOW GROUP SYSTEM, ESSENTIAL AND MINIMAL, AND THE SEATBACK MADE IN BRIGHT GLASS WITH MAGNETIC ACCESSORIES GIVES THE KITCHEN AN ELEGANT AND MODERN LOOK.



*Maxim  
n.1*





THE NEW YORK  
PUBLIC LIBRARY  
659908  
ASTOR, LENOX AND  
TILDEN FOUNDATIONS  
1916

# Maxim n.1 GOLA BIANCA

GLI ELEMENTI A GIORNO SONO IDEALI PER PERSONALIZZARE LA CUCINA E RENDERLA PROPRIA. IL COLOR SETA TROVA NEL PIANO IN MARMO KAESAR BROWN UN ACCOSTAMENTO IDEALE.

THE OPEN ELEMENTS ARE IDEAL FOR CUSTOMISING THE KITCHEN AND MAKING IT YOUR OWN. THE SILK COLOUR FINDS ITS IDEAL MATCH IN THE KAESAR BROWN MARBLE TOP.



# Maxim

GOLA BRILL

## n.2

LE ARMADIATURE DALLE GEOMETRIE SFALSATE E I PENSILI A VISTA DEL BANCONO E DELLA ZONA FORNO CREANO VANI CHE È POSSIBILE PERSONALIZZARE CON OGGETTI PERSONALI E D'ARREDO, DONANDO VIVACITÀ A UNA CUCINA DAL CARATTERE DETERMINATO. A ESALTARNE L'ELEGANZA, IL CONTRASTO DECISO E RAFFINATO TRA I COLORI BIANCO FRIANDA E DUNA.

THE CABINETS WITH UNEVEN GEOMETRIES AND OPEN WALL UNITS OF THE COUNTER AND OVEN AREA CREATES COMPARTMENTS THAT YOU CAN CUSTOMISE WITH PERSONAL OBJECTS AND FURNISHING, BESTOWING VIVACITY TO A KITCHEN WITH A STRONG PERSONALITY. THE DECIDED AND REFINED CONTRAST BETWEEN THE COLOURS DAMASK LINEN WHITE AND DUNE BRING OUT ELEGANCE.



Maxim  
n.2

LA PENISOLA CON LA PARTE FINALE A GIORNO SEPARA E ALLO STESSO TEMPO ARMONIZZA LA ZONA COOKING E LA ZONA LIVING.

THE PENINSULA WITH THE OPEN AND SEPARATES, WHILE AT THE SAME TIME HARMONISES, THE COOKING AND LIVING AREAS.





*Maxim  
n.2*

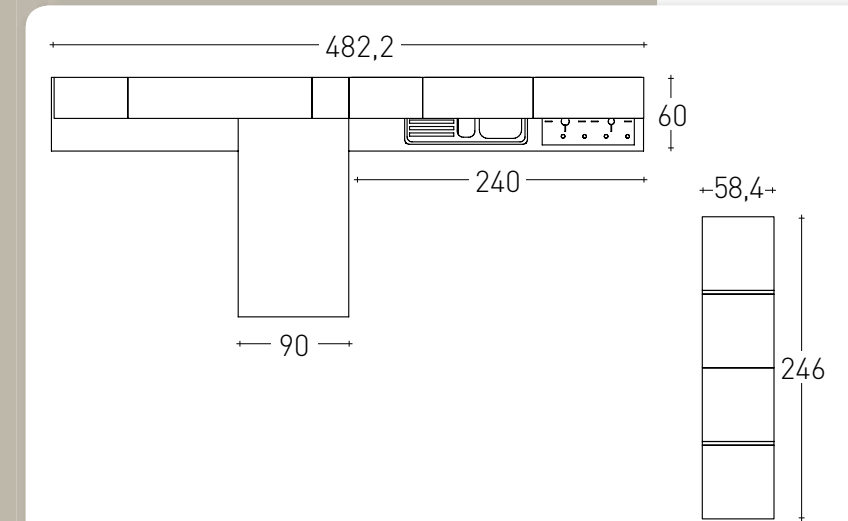

I PENSILI A VISTA SUL BANCONE CON FINALE A GIORNO RENDONO LA CUCINA UN LUOGO VISSUTO E CONFORTEVOLE. IL TOP È IN FENIX COLOR BRONZO DOHA.

THE OPEN WALL UNIT OVER THE COUNTER WITH OPEN AND MAKE THE KITCHEN A LIVED-IN AND COMFORTABLE PLACE. THE TOP IS IN FENIX, DOHA BRONZE COLOUR.



*Maxim  
n.2*



*Maxim*  
GOLA BRILL n. 2

TRA LE NOVITÀ, IL JOLLY EVO SOTTOPENSILE IN LAMIERA LACCATO BIANCO OPACO, IDEALE PER TENERE ORGANIZZATI SPEZIE E PICCOLI UTENSILI D'USO QUOTIDIANO.

AMONG THE NOVELTIES IS THE JOLLY EVO, UNDER-UNIT IN MATT WHITE LACQUERED SHEET METAL, IDEAL FOR KEEPING SPICES AND SMALL UTENSILS FOR EVERYDAY USE ORGANISED.



*Maximizing  
n.l.*



# Maxim

GOLA CORDA N. 3

UNA SOLUZIONE CHE METTE AL CENTRO DELLA CUCINA IL SUO GESTO PIÙ IMPORTANTE: CUCINARE. UN SISTEMA DI COLONNE, VANI E ARMADIATURE COMPATTO E ORGANIZZATO, IN CUI TUTTO È A PORTATA DI MANO, DOVE LE LINEE RIGIDE E SICURE GIOCANO CON I PIANI ANIMANDO LA CUCINA CON UN GUSTO CONTEMPORANEO E DINAMICO.

A SOLUTION THAT PUTS THE MOST IMPORTANT GESTURE OF THE KITCHEN AT THE CENTRE: COOKING. A COMPACT AND ORGANISED SYSTEM OF COLUMNS, COMPARTMENTS AND CABINETS WHERE EVERYTHING IS AT YOUR FINGERTIPS, WHERE THE RIGID AND CERTAIN LINES PLAY WITH PLANES, ANIMATING THE KITCHEN WITH A CONTEMPORARY AND DYNAMIC TASTE.





UN LOOK FRESCO E MODERNO PER UNA CUCINA IN CUI OGNI SPAZIO È RAZIONALIZZATO PER ESALTARNE EFFICACIA E FUNZIONALITÀ.

A FRESH AND MODERN LOOK FOR KITCHEN WHERE EVERY SPACE IS RATIONALIZED TO ADD SALT EFFECTIVENESS AND FUNCTIONALITY.

*Maxim  
n. 3*





*Maxim*  
GOLA CORDA n. 3

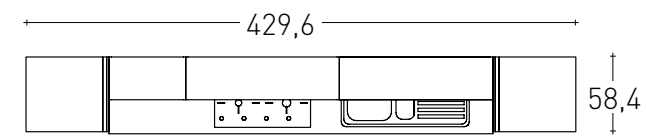

FRASSINO SETA

FRASSINO DUNA

TOP  
LAMINATO SPES. 4 CM  
COLORE SEGATO TINTO

PROTAGONISTA DELLA CUCINA È IL NUOVO COLOR CORDA UTILIZZATO PER GOLA SCAVATA E ZOCCOLO, CON IL CONTRAPPUNTO DEL PIANO IN SEGATO TINTO.

THE STAR OF THE KITCHEN IS THE NEW ROPE COLOUR, USED FOR HOLLOW GROOVE AND TOE-KICK, WITH THE COUNTERPOINT OF THE PAINTED LAMINATED TOP.







# Maxim

GOLA CORDA n. 3

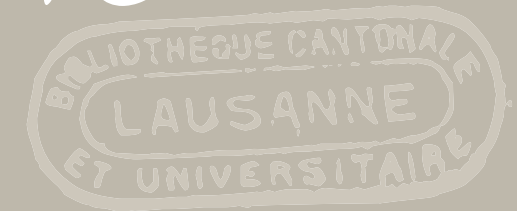

PROTAGONISTA DELLA CUCINA È IL NUOVO COLOR CORDA UTILIZZATO PER GOLA SCAVATA E ZOCCOLO, CON IL CONTRAPPUNTO DEL PIANO IN SEGATO TINTO.

THE STAR OF THE KITCHEN IS THE NEW ROPE COLOUR, USED FOR HOLLOW GROOVE AND TOE-KICK, WITH THE COUNTERPOINT OF THE PAINTED LAMINATED TOP.

# Maxim

## MANIGLIE / HANDLES



STOSA CUCINE TI OFFRE UNA VASTA SERIE DI MANIGLIE DA ABBINARE ALL'ANTA DEL MODELLO MAXIM: CROMATE, SATINATE E COLORATE, DALLA FORMA LINEARE O ARCUATA, SCEGLI TU QUELLA PIÙ ADATTA ALLO STILE CHE VUOI DARE ALLA TUA CUCINA.

STOSA CUCINE OFFERS YOU A WIDE RANGE OF HANDLES FOR THE MAXIM DOOR: CHROME-PLATED, SATIN-FINISH, COLOURED, LINEAR OR ARCHED ... CHOOSE THE ONE THAT BEST SUITS THE STYLE YOU WANT FOR YOUR KITCHEN.

MANIGLIA DI SERIE / STANDARD HANDLE



cod. MW0  
↔ 96/160 mm

Cromo lucido  
Interasse 160 mm per basi bombate  
Glossy chrome  
160mm centre distance for convex base units

MANIGLIE OPZIONALI / OPTIONAL HANDLES



cod. MW0A  
↔ 96/160 mm

Bianco opaco  
Interasse 160 mm per basi bombate  
Matt white  
160mm centre distance for convex base units



cod. MW0B  
↔ 96/160 mm

Cromo lucido  
Interasse 160 mm per basi bombate  
Glossy chrome  
160mm centre distance for convex base units



cod. MW0C  
↔ 96/160 mm

Argento  
Interasse 160 mm per basi bombate  
Silver  
160mm centre distance for convex base units

# Maxim

SETA E OVINA n. 4

GEOMETRIE PURE E VOLUMI RIGOROSI PER QUESTA SOLUZIONE IN CUI IL BANCONE CON FINALE A GIORNO INTERSECA LO SPAZIO LIVING, CREANDO OMOGENEITÀ AMBIENTALE. IL RUOLO INTERCAMBIABILE DEI PENSILI A VISTA LI DECLINA IN LIBRERIA O IN VANI PER OGGETTISTICA DI UTILITÀ QUOTIDIANA.

PURE GEOMETRIES AND PRECISE VOLUMES FOR THIS SOLUTION, WHERE THE COUNTER (WITH OPEN END PART) PROTRUDES INTO THE LIVING AREA TO CREATE A FEELING OF CONTINUITY. THE MULTIPURPOSE NATURE OF THE OPEN WALL UNITS MAKES THEM IDEAL AS BOOKCASES OR CONTAINERS FOR EVERYDAY ITEMS.



# Maxim n. 4

FRASSINO TINTO DUNA E SETA, MANIGLIA MW0 CROMO LUCIDO (STANDARD), TOP: LAMINATO SP. 4 CM. LUSERNA BIANCO.

DUNE AND SILK COLOURED ASH, MW0 GLOSSY CHROME HANDLE (STANDARD), LAMINATED TOP IN WHITE LUSERNA, 4CM THICK.



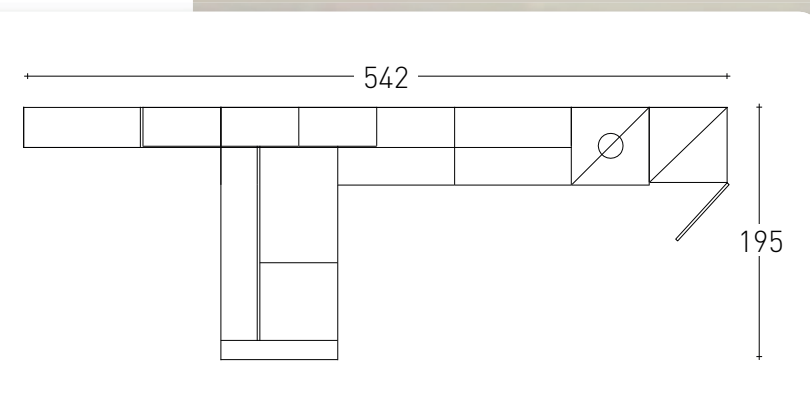

MANIGLIE ERGONOMICHE DAL DESIGN CONTEMPORANEO SPICCANO SULLE CORNICI DELLE ANTE A TELAIO, RICHIAMO CLASSICO CHE CONIUGA TRADIZIONE E MODERNITÀ. LA PENISOLA CON LA PARTE FINALE A GIORNO DIVIDE LA ZONA COOKING DALLA ZONA LIVING DELLA COMPOSIZIONE.

ERGONOMIC HANDLES WITH A CONTEMPORARY DESIGN STAND OUT AGAINST THE FRAMED DOORS - A CLASSIC NOTE COMBINING TRADITION WITH MODERNITY. THE PENINSULA WITH ITS OPEN END PART DIVIDES THE COOKING AND LIVING AREAS.





# Maxim n. 4

I PENSIERI E LE BASI DELLE CUCINE STOSA POSSONO AVERE SVARIATE APERTURE IN BASE ALLE ESIGENZE STRUTTURALI ED ERGONOMICHE DELLA COMPOSIZIONE. LA CUCINA MAXIM È PROGETTATA IN TUTTO TENENDO PRESENTE IL FRUTTORE FINALE, PER QUESTO GARANTISCE GRANDE FACILITÀ DI MOVIMENTO E UN'OTTIMALE UTILIZZAZIONE DELLO SPAZIO.

THE STOSA KITCHEN WALL AND BASE UNITS OFFER A VARIETY OF OPENING SYSTEMS DEPENDING ON THE STRUCTURAL AND ERGONOMIC REQUIREMENTS OF THE COMPOSITION. THE MAXIM KITCHEN IS DESIGNED ENTIRELY IN CONSIDERATION OF THE END USER, SO IT GUARANTEES PERFECT EASE OF MOVEMENT AND EXCELLENT USE OF SPACE.





# Maxim

SETH

## n. 5

LA RIPRODUZIONE GRAFICA TRIDIMENSIONALE DI QUESTA CUCINA È FRUTTO DI VOLUMI CHE GENERANO PROFONDITÀ DIVERSE. PENSILI A GIORNO, COLONNA FORNO E BASE FUNZIONI, PROPOSTI SU PIANI GEOMETRICAMENTE SFALSATI, ROMPONO GLI SCHEMI CLASSICI, INNOVANDO IL TOTAL LOOK DELLA CUCINA. RICHIAMI CLASSICHEGGIANTI, COME IL CAPPELLO DEI PENSILI E DELLE ARMADIATURE, ALTERNANO I SEGNI DELLA TRADIZIONE ALLE GEOMETRIE CONTEMPORANEE.

THE THREE-DIMENSIONAL GRAPHIC REPRODUCTION OF THIS KITCHEN IS THE RESULT OF VOLUMES THAT GENERATE DIFFERENT DEPTHS. THE OPEN WALL UNITS, OVEN TALL UNIT AND FUNCTIONAL BASE UNIT ARE ON GEOMETRICALLY STAGGERED LEVELS TO BREAK FREE FROM THE CLASSIC RESTRAINTS AND INNOVATE THE OVERALL LOOK OF THE KITCHEN. CLASSIC REFERENCES, LIKE THE TOP PANEL OF THE WALL UNITS, ADD TRADITIONAL TOUCHES TO THE CONTEMPORARY GEOMETRIES.





FINITURA: FRASSINO TINTO SETA, MANIGLIA MW0 CROMO LUCIDO (STANDARD); TOP: STRATIFICATO SP. 1,2 CM NERO FINITURA LARIX.

FINISH: SILK-COLOURED ASH, MW0 GLOSSY CHROME HANDLE (STANDARD), LAMINATED TOP WITH BLACK LARIX FINISH, 1,2CM THICK.

*Maxim*  
n. 5

# Maxim n. 5

LA BASE FUNZIONI È L'ESPRESSIONE MASSIMA DEL CRITERIO ERGONOMICO SU CUI RUOTA L'INTERO PROGETTO. I BLOCCHI AVANZATI RISPETTO ALLA ZONA FUOCHI AGEVOLANO L'UTENTE NELLA COTTURA DEL CIBO, FAVORENDO LE FASI DI PREPARAZIONE E DI LAVAGGIO. I FINALI LATERALI OTTIMIZZANO LO SPAZIO TRASFORMANDOSI IN UTILI DISPENSE A GIORNO.

THE FUNCTIONAL BASE UNIT IS THE FINEST EXPRESSION OF THE ERGONOMIC CRITERION AROUND WHICH THE ENTIRE DESIGN REVOLVES. THE BLOCKS THAT PROTRUDE IN RELATION TO THE HOB AREA MAKE IT EASIER FOR THE USER WHEN COOKING, PREPARING AND WASHING. THE FINISHING SIDE ELEMENTS OPTIMISE THE SPACE, BECOMING USEFUL OPEN STORAGE AREAS.

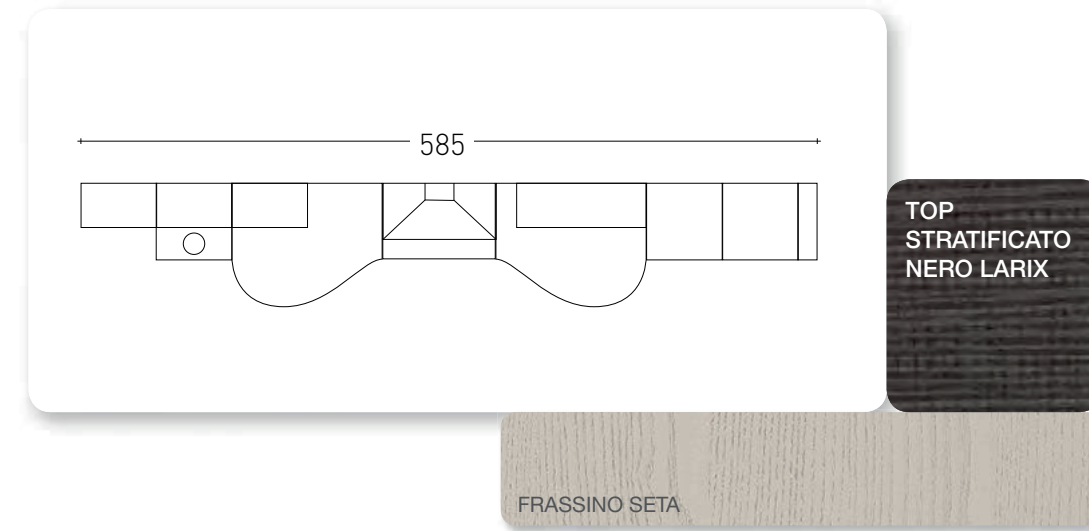

# Maxim

Bianco fiandra n. 6

LA SOLUZIONE TOTAL WHITE EVIDENZIA LA LUMINOSITÀ DI UN DESIGN LIBERO DA CONDIZIONAMENTI DECORATIVI. VOLUMETRIE IMPORTANTI TRACCIANO LA MATERICITÀ DELLA CUCINA, DANDO VITA A FORME COMPATTE CHE NON DISDEGNANO ELEMENTI VINTAGE, QUALI LA CAPPA, MA CHE IN PRIMIS EVIDENZIANO LE NOTE CONTEMPORANEE, COME L'ISOLA BANCONE COMPLETA DI TAVOLO DINING.

THE TOTAL WHITE SOLUTION HIGHLIGHTS THE LUMINOSITY OF A DESIGN THAT IS FREE FROM DECORATIVE CONDITIONING. IMPORTANT VOLUMES TRACE THE TEXTURE OF THE KITCHEN, CREATING COMPACT SHAPES THAT DON'T DISDAIN VINTAGE ELEMENTS, SUCH AS THE HOOD, BUT WHICH, FIRST AND FOREMOST, HIGHLIGHT THE CONTEMPORARY NOTES, SUCH AS THE ISLAND COUNTER, COMPLETE WITH DINING TABLE.





FINITURA: FRASSINO TINTO BIANCO FIANDRA, MANIGLIA MW0C ARGENTO (OPTIONAL), TOP: LAMINATO SP. 4 CM. CARIBE BIANCO.

FINISH: FLAX WHITE ASH, MW0C SILVER HANDLE (OPTIONAL), LAMINATED TOP WITH WHITE CARIBE FINISH, 4CM THICK.

*Maxim*  
n.6

MANIGLIA

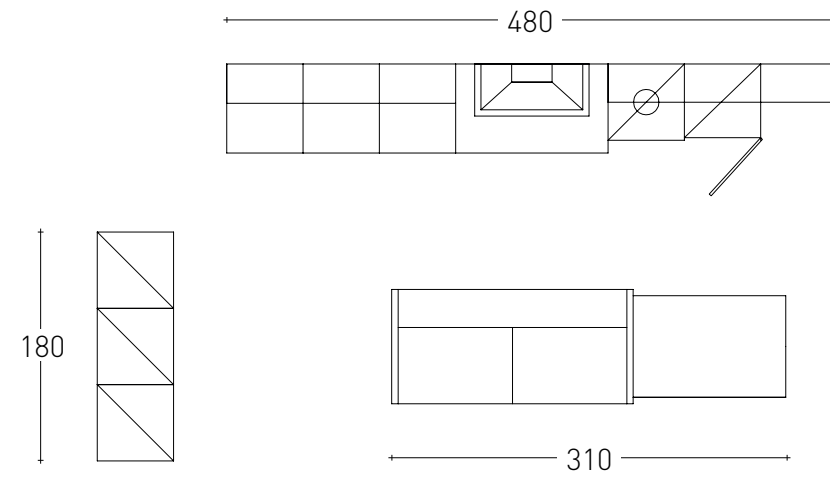

TOP  
LAMINATO  
CARIBE BIANCO

FRASSINO BIANCO FIANDRA



Maxim  
n.6

A FIANCO, LA MANIGLIA NELLA FINITURA BIANCO OPACO. LE CUCINE STOSA OFFRONO LE MIGLIORI SOLUZIONI PER LA PERSONALIZZAZIONE DELLA CUCINA. LE COLONNE H.152 CM. SONO PERFETTE PER OSPITARE IL FORNO CON APERTURA LATERALE.

ON LEFT, THE HANDLE IN THE MATT WHITE FINISH. STOSA CUCINE OFFER THE BEST SOLUTIONS FOR CUSTOM BUILT KITCHENS. THE 152 CM HIGH COLUMNS ARE PERFECT FOR HOUSING THE SIDE-OPENING OVEN.





FINITURA: FRASSINO TINTO BIANCO  
FIANDRA, MANIGLIA MW0C ARGENTO  
(OPTIONAL), TOP: LAMINATO SP. 4 CM.  
CARIBE BIANCO.

FINISH: FLAX WHITE ASH, MW0C SILVER  
HANDLE (OPTIONAL), LAMINATED TOP WITH  
WHITE CARIBE FINISH, 4CM THICK.



*Maxim*  
n. 6

L'ARMADIATURA DALLA LINEA RIGOROSA OFFRE UNA DISPENSA CAPIENTE. I TOP INATTACCABILI DA AGENTI TERMICI ED USURA, GARANTISCONO DURATA INALTERABILE NEL TEMPO.

THE CUPBOARDS WITH THEIR STRICT PROFILE OFFER AMPLE STORAGE SPACE. THE HEAT-RESISTANT TOPS ARE UNAFFECTED BY WEAR AND TEAR, GUARANTEEING A LONG WORKING LIFE.

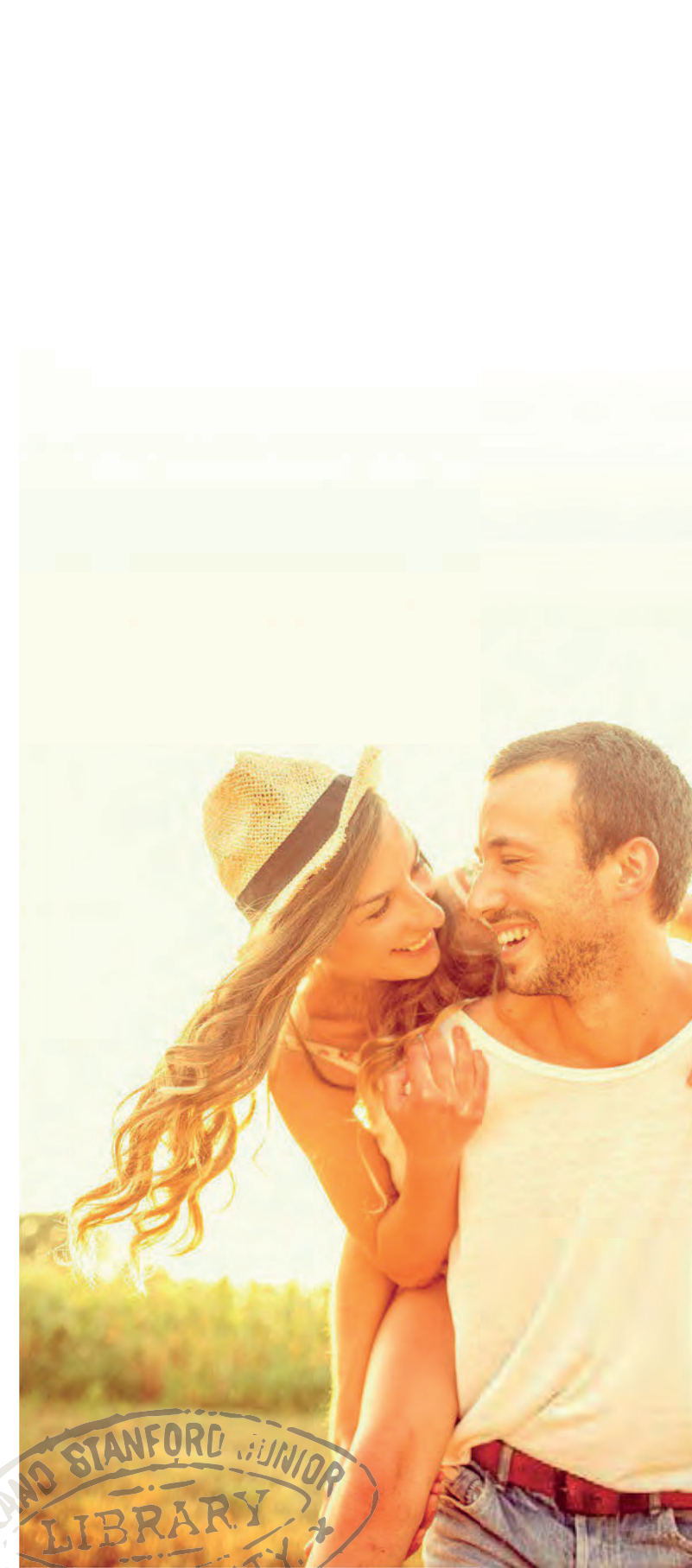





# Maxim

binaco fiandra e duna n. 7

LA GEOMETRIA PURA SI UNISCE AL DESIGN CURVILINEO DEL BANCONE, SOLUZIONI SEMPRE PIU' PERSONALIZZATE, CON ALTERNANZA DI VANI CHIUSI ED ELEMENTI A GIORNO, GRANDI ARMADIATURE E PENISOLE CHE BEN SI ADATTANO AL VIVERE CONTEMPORANEO. INFINITE LE SOLUZIONI CHE OFFRE LA NUOVA CUCINA MAXIM.

PURE GEOMETRY COMBINES WITH THE CURVED PROFILE OF THE COUNTER. INCREASINGLY CUSTOMISED SOLUTIONS ALTERNATING CLOSED AND OPEN ELEMENTS WITH LARGE CABINETS AND PENINSULAS TO FIT IT PERFECTLY WITH THE CONTEMPORARY LIFESTYLE. THE NEW MAXIM KITCHEN OFFERS ENDLESS SOLUTIONS.



MANIGLIA

# Maxim n. 7

FINITURA: FRASSINO TINTO DUNA E BIANCO  
FIANDRA, MANIGLIA MW0B CROMO LUCIDO  
(OPTIONAL), TOP: LAMINATO SP. 2 CM  
SCARLET BIANCO, LAMINATO SP. 4 CM LAVA.

FINISH: DUNE AND FLAX WHITE ASH, MW0B  
GLOSSY CHROME HANDLE (OPTIONAL),  
LAMINATED TOP WITH WHITE SCARLET  
FINISH - 2CM THICK, AND LAVA FINISH  
- 4CM THICK.





# Maxim n. 7

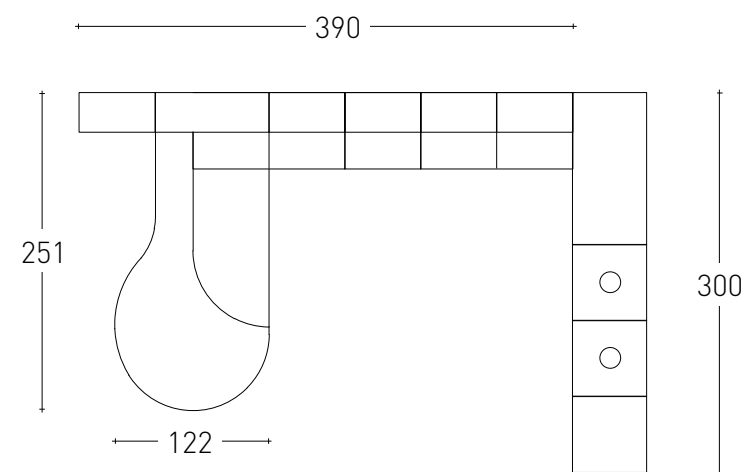

SPESSORI DIVERSI CREANO MOVIMENTO SUL TOP DEL BANCONE PENISOLA, DOVE IL TOP LAMINATO LAVA DISEGNA UNA SINUOSA CURVA SOPRA CON IL TOP SCARLETT BIANCO, IN UN GIOCO POLICROMO DI INCASTRI GEOMETRICI CHE SEPARA LA SUPERFICIE ADIBITA AL BREAK DA QUELLA PREPOSTA AL COOKING.

DIFFERENT THICKNESSES CREATE MOVEMENT ON THE PENINSULA COUNTER, WHERE THE LAVA LAMINATE TOP FORMS A SINUOUS CURVE ABOVE THE WHITE SCARLET TOP, IN A POLYCHROME GAME OF GEOMETRIC EFFECTS THAT SEPARATES THE SNACK AREA FROM THE COOKING AREA.



# Maxim n. 7



OGNI PARTICOLARE È ESPRESSIONE DI UN DESIGN GIOVANE FINALIZZATO ALLA FUNZIONALITÀ, COME LA BARRA SOTTOPENSILI PORTA OGGETTI, CON ILLUMINAZIONE A LED. L'ERGONOMIA METTE AL CENTRO DELLA CUCINA IL SOGGETTO CHE LA VIVE E CHE CON ESSA CONDIVIDE EMOZIONI TATTILI, VISIVE, OLFATTIVE.

EVERY DETAIL EXPRESSES YOUTHFUL DESIGN FOCUSING ON PRACTICALITY, LIKE THE UTENSIL RAIL UNDER THE WALL UNIT, WITH LED LIGHTING. ERGONOMICS PLACE THE KITCHEN USER AT THE CENTRE, OF EVERYTHING, PRIORITISING TACTILE, VISUAL AND OLFACTORY EMOTIONS.



# Maxim GOLA

## COMPOSIZIONI COMPOSITIONS



n.1  
PAG 4/5

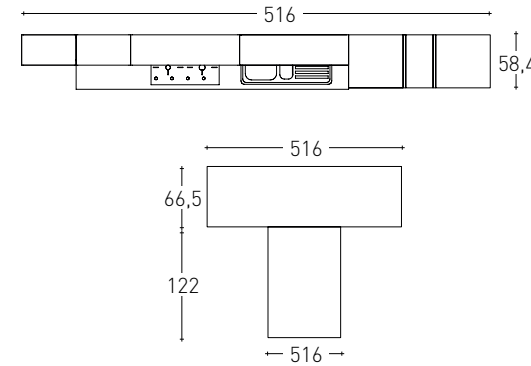

Finitura: frassino tinto bianco fiandra  
Elementi a giorno impiallacciati: colore seta  
Sistema di apertura: gola scavata in colore bianco opaco  
Top: marmo spess. 3 cm con bordo smusso inferiore colore Kaeser Brown lucido  
Sedie: S12 colore bianco fiandra con seduta in ecopelle  
Struttura tavolo per isola colore bianco fiandra

Finish: damask linen white dyed ash  
Open veneered elements: silk colour  
Opening system: Matt white coloured hollow groove  
Top: marble width 3 cm with the bevelled lower edge polished Kaeser Brown glossy colour  
Chairs: S12 damask linen white colour with eco-leather seat  
Table structure for damask linen, white coloured island



n.2  
PAG 14/15

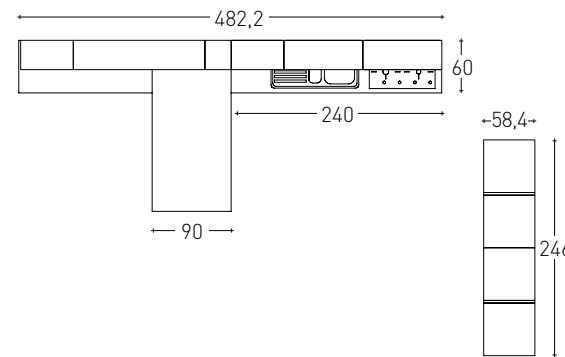

Finitura: frassino tinto bianco fiandra e duna  
Sistema di apertura: gola scavata in colore brill  
Top: fenix spess. 2 cm colore bronzo doha  
Sgabelli: Giulia seduta in cuoio colore bianco

Finish: damask linen white and dune-dyed ash  
Opening system: brill coloured hollow groove  
Top: fenix width 2 cm Doha bronze colour  
Stools: Giulia seat in white coloured leather

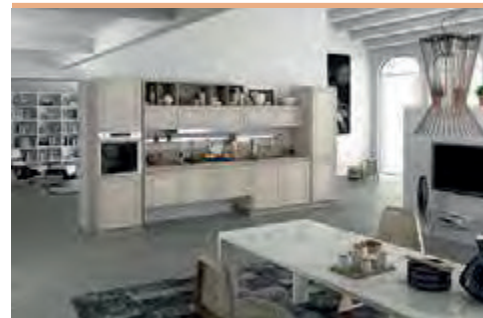

n.3  
PAG 26/27

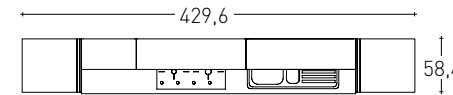

Finitura: frassino tinto seta  
Elementi a giorno impiallacciati: colore duna  
Sistema di apertura: new gola scavata in colore corda  
Zoccolo: new in colore corda  
Top: laminato spess. 4 cm colore segato tinto

Finish: silk dyed ash  
Veneered open elements: dune colour  
Opening system: new rope coloured hollow groove  
Toe-kick: new in rope-colour  
Top: laminate width 4 cm dyed marble chip colour

# Maxim MANTIGLIA

## COMPOSIZIONI COMPOSITIONS



n.4  
PAG 38/39

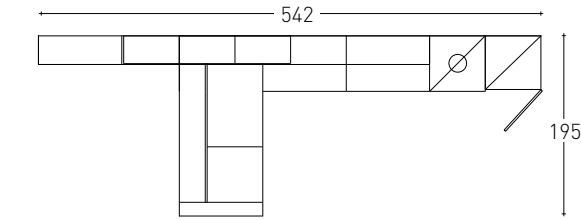

Finitura: frassino tinto duna e seta  
Maniglia MW0 cromo lucido (standard)  
Top: laminato sp. 4 cm. Luserna Bianco  
Sgabello Light

Finish: dune and silk ash  
Handle: MW0 glossy chrome (standard)  
Top: 4cm-thick laminate. Colour: white Luserna  
Stool: Light



n.5  
PAG 46/47

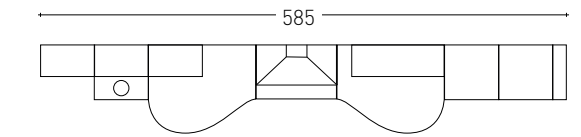

Finitura: frassino tinto Seta  
Maniglia MW0 cromo lucido (standard)  
Top: stratificato sp. 1,2 cm NERO finitura LARIX  
Tavolo Romagnolo  
Sedie con seduta in ecopelle

Finish: silk ash  
Handle: MW0 glossy chrome (standard)  
Top: 1.2cm-thick laminate with black larix finish  
Table: Romagnolo  
Chairs: eco-leather seat



n.6  
PAG 52/53

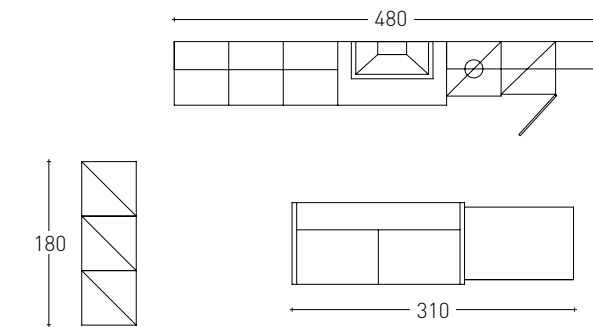

Finitura: frassino tinto bianco fiandra  
Maniglia MW0C Argento (optional)  
Top: laminato sp. 4 cm. Caribe Bianco  
Sedie con seduta in ecopelle

Finish: flax white ash  
Handle: MW0C silver (optional)  
Top: 4cm-thick laminate. Colour: white caribe  
Chairs: eco-leather seat



n.7  
PAG 62/63

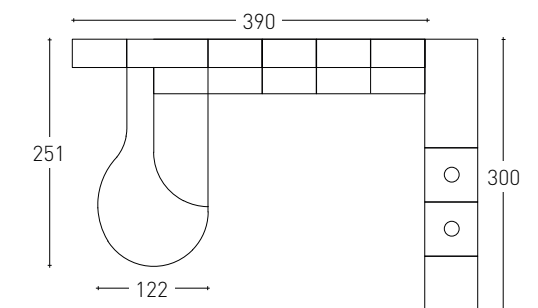

Finitura: frassino tinto Duna e Bianco Fiandra  
Maniglia MW0B Cromo lucido (optional)  
Top: Laminato sp. 2 cm SCARLET BIANCO, Laminato sp. 4 cm LAVA  
Sgabelli light

Finish: dune and flax white ash  
Handle: MW0B glossy chrome (optional)  
Top: laminate. Colour: white scarlet (2cm thick) and lava (4cm thick)  
Stools: Lightz

## SEDIE E SGABELLI COORDINATI / COORDINATED CHAIRS AND STOOLS



**Scarlet** SEDIA / CHAIR  
L 45 P 54 H sed. 44,5 H tot. 80 cm

Struttura metallo, seduta e schienale in bimerita nei colori bianco/trasparente, nero/trasparente, grigio/trasparente, arancione/trasparente, verde/trasparente, avorio/trasparente.  
Metal structure, seat and back in bi-material in colours: white/transparent, black/transparent, grey/transparent, orange/transparent, green/transparent, ivory/transparent.



**SPEEDSTER** SEDIA / CHAIR  
L 45 P 47 H sed. 47 H tot. 81 cm

Struttura cromo, seduta e schienale in acrilico nei colori bianco, arancione trasparente, viola trasparente, neutro trasparente, grigio fumo trasparente.  
Chrome structure, seat and back in acrylic, in colours: white, transparent orange, transparent violet, transparent neutral, transparent smoke grey.

## SEDIE E SGABELLI COORDINATI / COORDINATED CHAIRS AND STOOLS



**LIGHT** SEDIA / CHAIR  
L 40 P 40 H sed. 46 H tot. 79 cm

Struttura cromo, seduta e schienale colore nero.  
Chrome structure, black seat and back.



**LIGHT** SGABELLO / STOOL  
L 36 P 34 H sed. 67 H tot. 91 cm

Struttura cromo, seduta e schienale colore nero.  
Chrome structure, black seat and back.



**VENERE** SEDIA / CHAIR  
L 37 P 41 H sed. 47 H tot. 83 cm

Struttura cromo, seduta e schienale in cuoio colore bianco, marrone, nero, rosso, crema, corda, grigio.  
Chrome structure, seat and back in leather available in white, brown, black, red, cream, ecru, grey.



**VENERE** SGABELLO / STOOL  
L 37 P 34 H sed. 67 H tot. 93 cm

Struttura cromo, seduta e schienale in cuoio colore bianco, marrone, nero, rosso, crema, corda, grigio.  
Chrome structure, seat and back in leather available in white, brown, black, red, cream, ecru, grey.



**VALENTINA** SEDIA / CHAIR  
L 44,5 P 41,5 H sed. 47,5 H tot. 83,5 cm

Struttura e seduta legno.  
Wood structure and seat.



**RUDY** SGABELLO / STOOL  
L 37,5 P 34,5 H sed. 76,5 H tot. 96,5 cm

Sgabello telescopico con struttura colore cromo e seduta in policarbonato colore trasparente.  
Telescopic stool with chrome structure and transparent polycarbonate seat.



**GIULIA** SEDIA / CHAIR  
L 46 P 42 H sed. 47 H tot. 87 cm

Sedia rivestita in cuoio, seduta e schienale colore bianco, marrone, nero, rosso, crema, corda, grigio.  
Leather-covered chair, seat and back available in white, brown, black, red, cream, ecru, grey.



**GIULIA** SGABELLO / STOOL  
L 43 P 34 H sed. 66 H tot. 90 cm

Sgabello rivestito in cuoio, seduta e schienale colore bianco, marrone, nero, rosso, crema, corda, grigio.  
Leather-covered stool, seat and back available in white, brown, black, red, cream, ecru, grey.



**SEDIA / CHAIR S16**  
L 43 P 50 H sed. 46 H tot. 92,5 cm

Struttura legno, seduta ecopelle.  
Wood structure, seat in eco-leather.



**SGABELLO / STOOL SGA08**  
L 39 P 42 H sed. 66 H tot. 108 cm

Struttura legno, seduta ecopelle.  
Wood structure, seat in eco-leather.

## TAVOLI TABLES



chiuso / closed

aperto / open

### MERCURIO TAVOLO ALLUNGABILE / EXTENDABLE TABLE

L 90 / 150 - 136 / 196 P 90 H 76 cm

Tavolo allungabile con struttura in alluminio zero chimico o cromo lucido. Piano melaminico spessore 1,8 cm disponibile nelle finiture magnolia o rovere grigio. Prolunga 60 cm.  
Extendable table with structure in chemical zero aluminium or glossy chrome. 1.8 cm thick melamine top available in magnolia or grey oak finish. Extension 60 cm.



chiuso / closed

aperto / open

### CUBO TAVOLO ALLUNGABILE / EXTENDABLE TABLE

L 140 / 200 P 80 H 75 cm

Tavolo allungabile piano vetro bianco o nero, piano laminato bianco, magnolia, rovere scuro.  
Extendable table, white or black glass surface, lacquered surface in white, magnolia, dark oak.



### ROMAGNOLO TAVOLO ALLUNGABILE / EXTENDABLE TABLE

L 140 P 80 H 78 cm

Piano impiallacciato sp. 3 cm, H. tavolo 80 cm. 2 Prolunghe da 50 cm. ciascuna.  
Veneered top 3cm thick, table H 80cm. Two extensions, each measuring 50cm.



chiuso / closed

aperto / open

### VENERE TAVOLO ALLUNGABILE / EXTENDABLE TABLE

L 160 / 210 P 90 H 73,8 cm

Tavolo allungabile piano vetro bianco e nero, struttura cromo, bianco e nero.  
Extendable table, white and black glass surface, structure in chrome, white or black.



### LAMINATO TAVOLO FISSO / FIXED TABLE

L 100/125/150 P 80 H 78 cm

Tavolo fisso con struttura in alluminio, piano in laminato sp. 4 cm ( per le finiture disponibili vedi pagina 78 Piani 4 cm bordo pari).  
Fixed table with aluminium structure, 4cm-thick laminate top (for the finishes, see page 78, 4cm tops with same edge)..



chiuso / closed



aperto / open

### LAMINATO TAVOLO ALLUNGABILE / EXTENDABLE TABLE

L 100/125/150 P 80 H 78 cm

Tavolo allungabile con struttura in alluminio, piano in laminato sp. 4 cm ( per le finiture disponibili vedi pagina 78 Piani 4 cm bordo pari).  
Extendable table with aluminium structure, 4cm-thick laminate top (for the finishes, see page 78, 4cm tops with same edge)

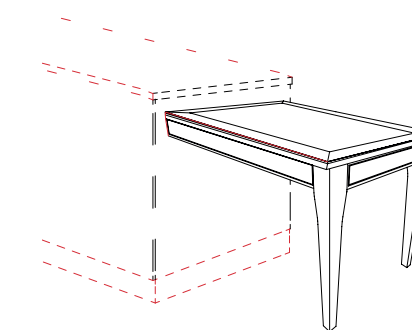

### STRUTTURA TAVOLO PER ISOLA TABLE FOR ISLAND STRUCTURE

Piano impiallacciato sp. 3 cm, H. tavolo 75 cm.  
Veneered top 3cm thick, table H 75cm.

## TIPOLOGIA STRUTTURA / TYPES OF STRUCTURE

Fianchi strutturali laminati o impiallacciati sp. 18 mm finiti nei bordi frontali, superiori, inferiori più lato esterno a vista, con interno sempre champagne come scocca (optional). Laminated or veneered structural sides, 18-mm thick, finished on front, upper and lower edges plus visible exterior, with interior always in champagne like the structure (optional).



## MANIGLIE / HANDLES

MANIGLIA DI SERIE / STANDARD HANDLE



**cod. MW0**  
↔ 96/160 mm  
Cromo lucido  
Interasse 160 mm per basi bombate  
Glossy chrome  
160mm centre distance for convex base units

MANIGLIE OPZIONALI / OPTIONAL HANDLES



**cod. MW0A**  
↔ 96/160 mm  
Bianco opaco  
Interasse 160 mm per basi bombate  
Matt white  
160mm centre distance for convex base units



**cod. MW0B**  
↔ 96/160 mm  
Cromo lucido  
Interasse 160 mm per basi bombate  
Glossy white  
160mm centre distance for convex base units



**cod. MW0C**  
↔ 96/160 mm  
Argento  
Interasse 160 mm per basi bombate  
Silver  
160mm centre distance for convex base units

GOLE SCAVATE COLORI / GROOVE COLOURS



## TIPOLOGIA ANTE / TYPES OF DOOR

TELAIO CON BUGNA IN LEGNO FRASSINO / FRAME WITH PANEL IN ASH



Anta piena tinta SETA  
SILK solid painted door



Anta vetro specchio Sol  
tinta SETA (h. 36-48 cm)  
SILK stained reflective Sol  
glass door (h. 36-48 cm)



Anta vetro specchio Sol  
tinta SETA (h. 60-72 cm)  
SILK stained reflective Sol  
glass door (h. 60-72 cm)



Anta vetro specchio Sol  
tinta SETA (h. 96-132 cm)  
SILK stained reflective Sol  
glass door (h. 96-132 cm)



Cesto pieno tinta SETA  
SILK solid painted deep  
drawer



Cassetto tinta SETA  
SILK painted drawer



Anta piena tinta BIANCO  
FIANDRA  
FLAX WHITE solid painted  
door



Anta vetro specchio Sol  
tinta BIANCO FIANDRA (h.  
36-48 cm)  
WHITE FLAX stained  
reflective Sol glass door (h.  
36-48 cm)



Anta vetro specchio Sol  
tinta BIANCO FIANDRA (h.  
60-72 cm)  
WHITE FLAX stained  
reflective Sol glass door (h.  
60-72 cm)



Anta vetro specchio Sol  
tinta BIANCO FIANDRA (h.  
96-132 cm)  
WHITE FLAX stained  
reflective Sol glass door (h.  
96-132 cm)



Cesto pieno tinta BIANCO  
FIANDRA  
FLAX WHITE solid painted  
deep drawer



Cassetto tinta BIANCO FIANDRA  
FLAX WHITE painted drawer



Anta piena tinta DUNA  
DUNE solid painted door



Anta vetro specchio Sol  
tinta DUNA (h. 36-48 cm)  
DUNE stained reflective Sol  
glass door (h. 36-48 cm)



Anta vetro specchio Sol  
tinta DUNA (h. 60-72 cm)  
DUNE stained reflective Sol  
glass door (h. 60-72 cm)



Anta vetro specchio Sol  
tinta DUNA (h. 96-132 cm)  
DUNE stained reflective Sol  
glass door (h. 96-132 cm)



Cesto pieno tinta DUNA  
DUNE solid painted deep  
drawer



Cassetto tinta DUNA  
DUNE painted drawer

TIPOLOGIE ZOCCOLI / TYPES OF TOE-KICK

H. 12 cm



PVC rivestito con foglia  
impiallacciata colore Seta  
H. 12 cm (standard)  
PVC covered with Silk-co-  
loured veneer leaf, H.12cm  
(standard)

H. 12 cm



PVC rivestito con foglia  
impiallacciata colore  
Bianco fiandra  
H. 12 cm (standard)  
PVC covered with Flax  
White coloured veneer leaf,  
H.12cm (standard)

H. 12 cm



PVC rivestito con foglia  
impiallacciata colore Duna  
H. 12 cm (standard)  
PVC covered with Dune-co-  
loured veneer leaf, H.12cm  
(standard)

H. 12/15 cm



PVC colore specchio  
H. 12/15 cm (opzionale).  
Mirrored PVC H.12/15cm  
(optional)

H. 15 cm



PVC colore piombo opaco  
H. 12 cm (opzionale).  
PVC in matt lead colour,  
H.12cm (optional)

H. 15 cm



PVC colore inox  
H. 12 cm (opzionale).  
PVC in stainless steel  
colour, H.12cm (optional)

H. 15 cm



PVC colore inox  
H. 12 cm (opzionale).  
PVC in stainless steel  
colour, H.12cm (optional)

H. 12/15 cm



PVC colore corda  
H. 12/15 cm (opzionale).  
PVC in ecru colour, H.12cm  
(optional)



## PIANI DI LAVORO / WORKTOPS

### PIANI STRATIFICATI SP. 1,2 CM PARI / LAMINATED TOPS, 1.2CM THICK, STRAIGHT

TIPOLOGIA PROFILO  
/ PROFILE TYPE



COLORI STRATIFICATO  
/ LAMINATE COLOURS



Lava, finitura MIKA  
Lava, MIKA finish



Bianco Decò, finitura ERRE  
Decò White, ERRE finish



Caribe Bianco finitura MIKA  
White Caribe, MIKA finish



Antracite, finitura ERRE  
Anthracite, ERRE finish



Scarlet Bianco, finitura MIKA  
White Scarlet, MIKA finish



Nero, finitura LARIX  
Black, LARIX finish

### LAMINATO SP. 2 CM BORDO ABS / LAMINATE 2 CM THICK ABS EDGE

TIPOLOGIA PROFILO  
/ PROFILE TYPE



COLORI LAMINATO  
/ LAMINATE COLOURS



Lava 3329 porfido nero finitura MIKA  
Lava 3329 black porphyry finish MIKA

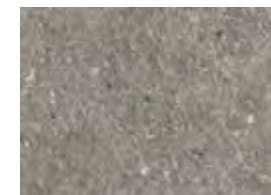

Pietra Vecchia 3324 finitura MIKA  
Pietra Vecchia 3324 finish MIKA



Pietra Serena 3326 finitura CLIFF  
Pietra Serena 3326 finish CLIFF



Sahara 3327 finitura CLIFF  
Sahara 3327 finish CLIFF



Sabbia finitura 0201 CLIFF  
Sand finish 0201 CLIFF

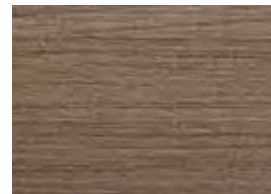

Olmo Mercurio 4539 finitura ALEVÈ  
Mercurio Elm 4539 ALEVÈ finish



Grigio Roccia bordo ABS finitura ALEVÈ  
Rock Grey ABS edge Rock Grey  
Rough-Hewn

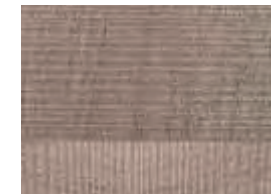

Pietra Chiara bordo ABS finitura ALEVÈ  
Light Stone ABS edge Light Stone  
Rough-Hewn

### LAMINATO SP. 4 - 6 CM. BORDO UNICOLOR / LAMINATE 4 - 6 CM THICK SINGLE-COLOUR EDGE

TIPOLOGIA PROFILO  
/ PROFILE TYPE



Profilo Alluminio o Bordo pari  
Aluminum Profile or Even Edge

COLORI LAMINATO  
/ LAMINATE COLOURS



Moka - Mocha



Sabbia - Sand

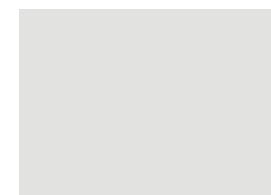

Bianco - White

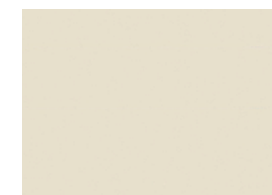

Avorio - Ivory



Grafite - Graphite

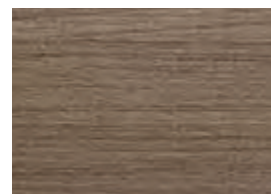

Olmo Mercurio finitura ALEVÈ  
Mercurio Elm ALEVÈ finish



Olmo Bianco finitura ALEVÈ  
White Elm ALEVÈ finish



Rovere Barroque finitura ALEVÈ  
Barroque Oak ALEVÈ finish

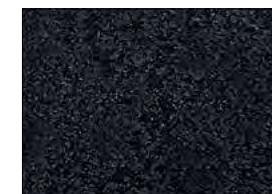

NERO finitura PIETRA  
BLACK STONE finish

## PIANI DI LAVORO / WORKTOPS

### LAMINATO SP. 4 CM. RAGGIO 2 MM. / LAMINATE 4 CM THICK, RADIUS 2 MM.

TIPOLOGIA PROFILO  
/ PROFILE TYPE



Raggio 2 mm - 2 mm radius.

COLORI LAMINATO  
/ LAMINATE COLOURS



Lava porfido nero finitura MIKA  
Lava black porphyry finish MIKA



Pietra Vecchia finitura MIKA  
Pietra Vecchia 3324 finish MIKA



Pietra Serena finitura CLIFF  
Pietra Serena finish CLIFF



Sahara finitura CLIFF  
Sahara finish CLIFF



Sabbia finitura CLIFF  
Sand finish CLIFF



Caribe Bianco finitura MIKA  
White Caribe 98446 finish MIKA



Corten Sabbia 3330 finitura MIKA  
Sand Corten 3330 finish MIKA



Glitter Bianco finitura MIKA  
White Glitter finish MIKA



Luserna Bianco finitura LUNA  
White Luserna finish LUNA



Scarlet Bianco finitura MIKA  
White Scarlet finish MIKA



Sparkle Avana finitura OSL  
Havana Sparkle OSL finish

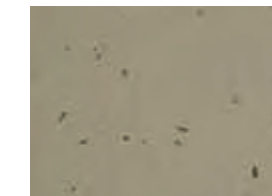

Sparkle Corda finitura OSL  
Cord Grey Sparkle OSL finish



Sparkle Nero finitura OSL  
Black Sparkle OSL finish

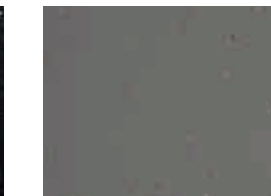

Sparkle Grigio finitura OSL  
Grey Sparkle OSL finish



Sparkle Bianco finitura OSL  
White Sparkle OSL finish

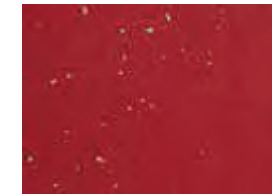

Sparkle Rosso finitura OSL  
Red Sparkle OSL finish



Porfido Principe finitura MIKA  
Principe Porphyry MIKA finish



Stromboli finitura LUNA  
Stromboli LUNA finish



Betulla finitura FLATTING  
Birch FLATTING finish



Bianco Decò finitura ERRE  
Decò White ERRE finish

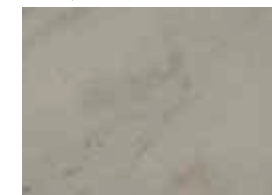

Marmo Canova finitura Lucido  
Canova Marble Glossy finish



Marmo Jura  
Jura marble

## OKITE / OKITE

TIPOLOGIA PROFILI  
/ PROFILE TYPE

COLORI OKITE  
/ OKITE COLOUR

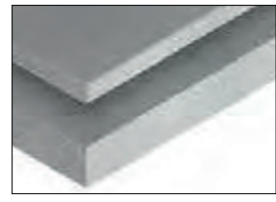

Bianco Carrara - Carrara white



Grigio - Grey



Grigio Nordico - Nordic gray



Crema Botticino - Botticino cream



Crema Marfil - Marfil cream

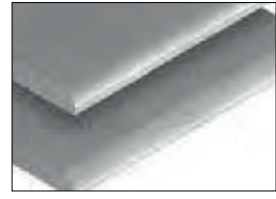

Gold Stone

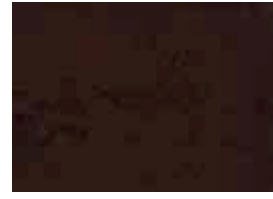

Marron Emperador



Nero Etna - Etna Black



Bianco Cortina - Cortina White



Nero Assoluto - Absolute Black



Profilo F  
F profile



Piazza del campo



Grigio Stromboli - Stromboli Gray



Paestum



Roman Stone



Jerusalem Stone



Bianco - White



Grigio Chiaro - Light Gray



Crema - Cream



Bianco Assoluto - Absolute White



Beige Royal

## INOX / STAINLESS STEEL

PROFILO INOX  
/ STAINLESS STEEL PROFILE

SPessori DISPONIBILI  
/ AVAILABLE THICKNESS

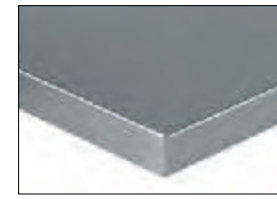
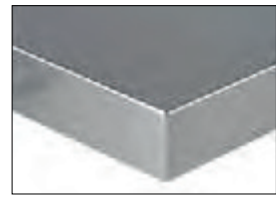

Spessore 3 cm - 3 cm thick

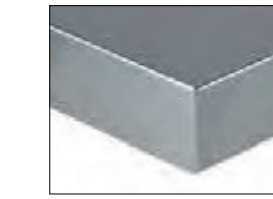

Spessore 6 cm - 6 cm thick

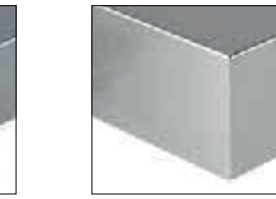

Spessore 10 cm - 10 cm thick

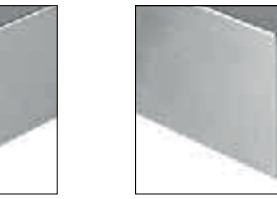

Spessore 15 cm - 15 cm thick

## PIANI DI LAVORO / WORKTOPS

### QUARZO / QUARTZ

TIPOLOGIA PROFILO  
/ PROFILE TYPE

COLORI QUARZO  
/ QUARTZ COLOUR



Graniglia grigio - Grey grit

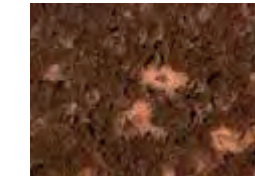

Graniglia marrone - Brown grit

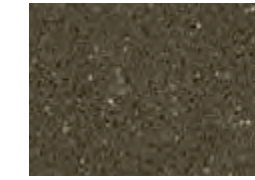

Grigio fango - Mud Grit



Titanium - Titanium

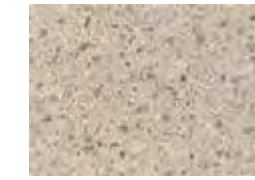
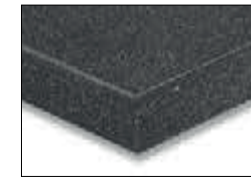

Beige duna - Dune beige



Bianco paloma - Paloma white

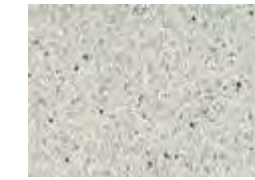

Bianco Sariba - Sariba white

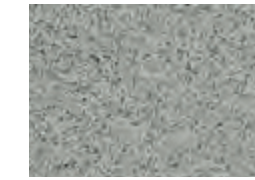

Grigio cenere - Ash grey

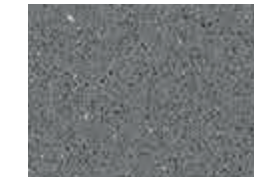

Grigio Serena - Serena grey



Otello



Beige Arena



Corniola - Cornelian



Diamante - Diamond



Maron canela

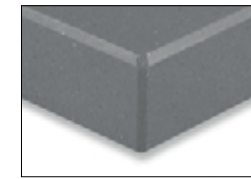

Nero S.M. - S. M. black



White sand

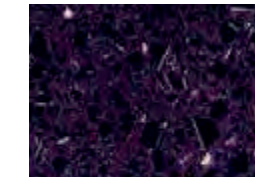

Starlight Ca' Pisani



Spacco diamante - Diamond Cleft



Spacco grigio - Grey cleft



Spacco porfirico  
Porphyry-colour work

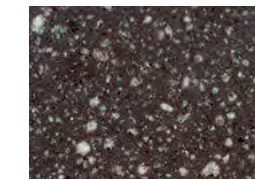

Porfirico lucido  
Bright porphyry colour



Spacco bianco - White Cleft



Spacco beige - Beige cleft



Spacco marrone - Brown cleft



Spacco nero - Black cleft



Grey amazon leather



Vitrurio Sand Tatum



Cloudy Beige Tatum



Cloudy White Tatum

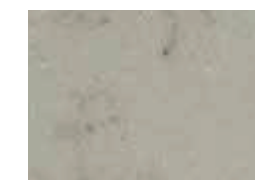

Veined Michelangelo



Veined Decò



Veined Baroque

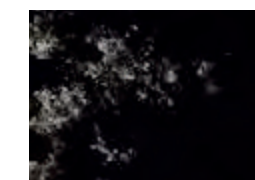

Veined Africa



Veined Titan



Veined Cream



Bianco 1776 - White 1776

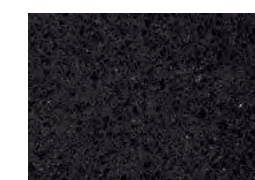

Crystal Pure Black



Grey Sand Ma Lucido  
Polished Grey Sand Ma



## MARMO SP. 3 CM. / MARBLE 3 CM THICK

TIPOLOGIA PROFILO  
/ PROFILE TYPE

COLORI MARMO  
/ MARBLE COLOURS



Bianco Carrara - Carrara white



Arabescato - Arabesqued



Calacatta



Verde Guatemala



Travertino

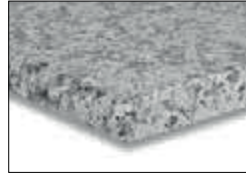

Giallo ocre satin  
Yellow ocher satin



Sahara gold  
(satinato - satin)



Petit granit  
(lucido - gloss)



Petit granit  
(levigato - smoothed)



Petit granit (fiammato patinato -  
iridescent patina)

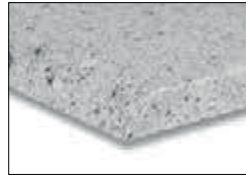

Kaeser brown  
(lucido - gloss)

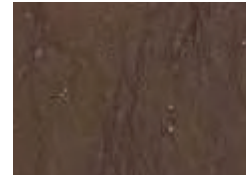

Kaeser brown  
(levigato - smoothed)



Kaeser brown (fiammato patinato -  
iridescent patina)



Grabla  
(levigato - smoothed)



Grabla velvet



Sea shore  
(lucido - gloss)



Sea shore  
(levigato - smoothed)



Sea shore velvet

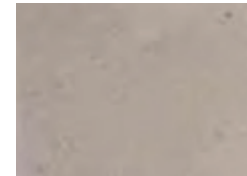

Pietra del Carso  
(levigato - smoothed)

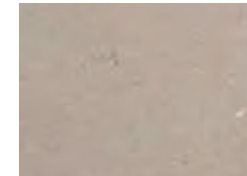

Pietra del Carso velvet

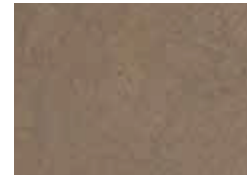

Mizar grey  
(lucido - gloss)



Mizar grey  
(levigato - smoothed)



Mizar grey (fiammato patinato -  
iridescent patina)

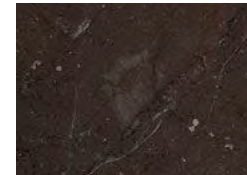

Ariel grey  
(lucido - gloss)

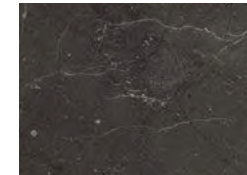

Ariel grey  
(levigato - smoothed)



Ariel grey velvet

## GRANITO SP. 3 CM / GRANITE 3 CM THICK

COLORI GRANITO  
/ GRANITE COLOURS



Granito rosa - Pink granite



Granito grigio - Grey granite



Granito ghiandone grigio  
Grey Ghiandone granite

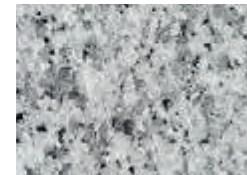

Granito bianco sardo  
Sardinian white granite



Nero assoluto fiammato patinato  
Absolute black iridescent patina



Toak purple  
(lucido - gloss)



Toak purple  
(levigato - smoothed)

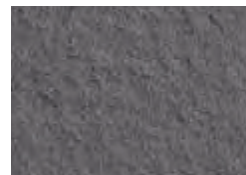

Toak Purple (fiammato patinato -  
iridescent patina)

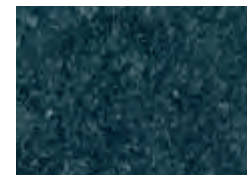

Granito nero africa



Granito giallo veneziano  
Venetian yellow granite

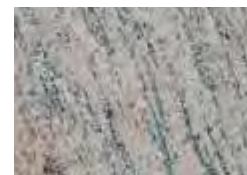

Granito River rosa  
River pink granite

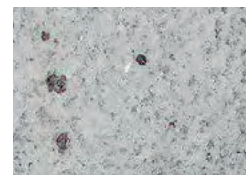

Granito kashmir white  
Kashmir white granite



Nero assoluto lucido  
Absolute black gloss



**G\* GRASS**

IL PROGRAMMA COMPLETO  
DI CASSETTI VERSATILE  
DAL DESIGN ESCLUSIVO,  
UNICO E FUNZIONALE

THE COMPLETE RANGE OF  
VERSATILE DRAWERS WITH  
A UNIQUE, EXCLUSIVE AND  
PRACTICAL DESIGN



**SPONDE STANDARD**  
Sponde scatolate in acciaio.  
Il sistema completo, preciso e  
personalizzato.

**STANDARD SIDES**  
The complete, accurate and tailor-  
made system.



**GUIDE**  
Sistema di apertura, ad estrazione  
totale. Standard - Ammortizzate -  
Push-pull.

**RUNNERS**  
Full-extraction opening system.  
Standard - Damped - Push-pull.

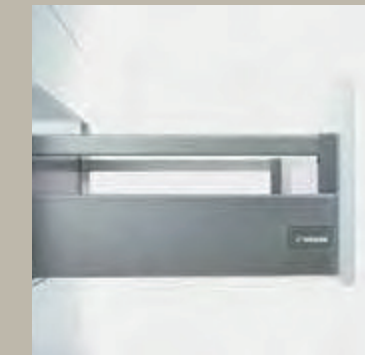

**SPONDE INOX OPTIONAL**  
Sponde scatolate in acciaio inox  
dal design elegante, ed eccellenti  
proprietà di scorrimento.

**OPTIONAL STAINLESS STEEL  
SIDES**  
Box-type stainless steel sides  
featuring an elegant design and  
excellent sliding.



**ACCESSORI**  
Antisgancio di serie: su tutta la  
gamma, integrabile a richiesta  
col sistema di sicurezza  
apertura per bambini.

**ACCESSORIES**  
Anti-release safety device  
fitted as standard on the whole  
range. Upon request, it can  
be combined with the safety  
opening system for kids.

Il passaggio a GRASS ha consentito di proporre l'intera gamma di elementi estraibili della STOSA sotto un'unica configurazione di sponde carenate che, oltre a soddisfare il fattore estetico, con le eleganti finiture in acciaio, conferiscono anche al prodotto di base un elevato standard qualitativo, il tutto abbinato ad una estrema coerenza in tutta la linea di prodotti siano essi standard che ridotti, basata sull'estrema scorrevolezza, resistenza e stabilità delle guide.

Thanks to the changeover to GRASS, the entire range of STOSA pull-out elements now has a single configuration with streamlined side panels. Apart from the aesthetic aspect (with their elegant steel finish), they also provide the product with a high quality standard and guarantee design coherency throughout the line, for both standard and reduced products. These runners ensure optimum smoothness, resistance and stability.

33 MULTIMEDIA STUDIO

Graphic concept

Copying

ARCHIVIO STOSA

Images

BIEFFE

Colour separation

LA PIEVE

Print

OCTOBER 2014





## Stosa S.p.A.

**STAB., SEDE AMM.VA E RECAPITO POSTALE:**

S.S. Cassia, Km. 149,5  
53040 Radicofani (SI) Italy

**GPS:**

N 42° 53' 50,6"  
E 11° 45' 53,5"

**INFO:**

tel. +39 0578 5711 r.a.  
fax +39 0578 50088

**INFO LINE:**

840 000 691

[www.stosa.it](http://www.stosa.it)

[stosa@stosa.it](mailto:stosa@stosa.it)



MPA03219