

# MOOD



**STOSA**  
CUCINE

# STOSA

## UNA FAMIGLIA ITALIANA. 50 ANNI DI STORIA E UNA SOLA GRANDE PASSIONE: LA CUCINA.

DA 50 ANNI PRODUCIAMO SOLO CUCINE, CREATE E PRODOTTE PER MIGLIORARE LA VITA DI CHI, OGNI GIORNO, VIVE NELLO SPAZIO PIÙ CONVIVIALE DELLA CASA. PROGETTIAMO E REALIZZAMO ESCLUSIVAMENTE IN ITALIA PRODOTTI ECCELLENTI NELLA QUALITÀ, REALMENTE SOSTENIBILI PER OGNI FAMIGLIA ITALIANA E PER I GIOVANI. ECCO PERCHÉ UNA CUCINA STOSA NASCE DA VALORI AUTENTICI COME IMPEGNO, ONESTÀ, RISPETTO E ORIGINALITÀ. IN ITALIA E IN OLTRE 40 PAESI NEL MONDO, CON UN MERCATO IN COSTANTE ESPANSIONE. IMPEGNO PER DARE IL MEGLIO DI NOI ATTRAVERSO OGNI SINGOLA CUCINA, DIRETTAMENTE A CASA TUA. ONESTÀ PER TRASFORMARE I NOSTRI PROGETTI IN SPAZI DI VITA DAVVERO SOSTENIBILI. RISPETTO PER LA NATURA CHE CI CIRCONDA E PER TUTTA LA FILIERA PRODUTTIVA. ORIGINALITÀ PER ESSERE SEMPRE PIÙ COMPETITIVI NELL'INNOVAZIONE TECNOLOGICA E FUNZIONALE. È COSÌ CHE OGNI GIORNO COSTRUIAMO LE NOSTRE CUCINE. PENSANDO A TE.

**STOSA, AN ITALIAN FAMILY. 50 YEARS OF HISTORY AND ONE GREAT PASSION: KITCHENS.**

FOR 50 YEARS WE'VE BEEN PRODUCING ONLY KITCHENS, DESIGNED AND BUILT FOR THOSE WHO ENJOY SPENDING TIME IN THE MOST WELCOMING ROOM IN THE HOME. OUR PRODUCTS, DESIGNED AND MADE ENTIRELY IN ITALY, STAND OUT FOR THEIR QUALITY YET ARE AFFORDABLE FOR ITALIAN FAMILIES AND YOUNG PEOPLE. BECAUSE A STOSA KITCHEN IS BASED ON AUTHENTIC VALUES LIKE COMMITMENT, HONESTY, RESPECT AND ORIGINALITY - IN ITALY AND A FURTHER 40 COUNTRIES WORLDWIDE, WITH A CONSTANTLY GROWING MARKET. COMMITMENT TO OFFER OUR BEST IN EVERY SINGLE KITCHEN, DIRECTLY IN YOUR OWN HOME. HONESTY TO TURN OUR DESIGNS INTO TRULY SUSTAINABLE LIVING AREAS. RESPECT FOR THE NATURE SURROUNDING US AND FOR THE WHOLE PRODUCTION CHAIN. ORIGINALITY TO BE MORE AND MORE COMPETITIVE WITH REGARDS TECHNOLOGICAL AND PRACTICAL INNOVATION. THAT'S HOW WE BUILD OUR KITCHENS EVERY DAY. THINKING OF YOU.









**Composizione 01**

**Basi** in laccato Pomice opaco con un inserto cesto in Olmo Cenere. **Pensili superiori** in laccato Pomice opaco senza presa maniglia. **Pensile Maxi** in filo vetro Eclettica Grigio Piacenza opaco. **Colonne** in Olmo Cenere con elementi Tetris impiallacciati Olmo Cenere. **Schienali interbasi Liberty** in finitura Fenix come top.

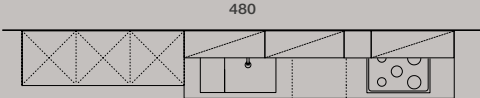
Matt Pumice varnished **bases** with Ash Olmo basket insert. Matt Pumice varnished **upper wall units** without handle. **Maxi wall unit** in matt Eclettica Piacenza Gray coloured glass. Ash Olmo tall units with Tetris Ash Olmo veneered elements. **Liberty interbase back panels** in Fenix finish as a top.

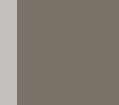

-   
 Olmo Cenere  
Ash grey Elm
-   
 Laccato Pomice  
Pumice Lacquered
-   
 Grigio Piacenza (Eclettica)  
Piacenza Grey (Eclettica)





Ricerca semplicità  
*Simplified search*



Non Chiamateli solo Accessori!  
*Don't just call them accessories!*







### Composizione 02

Basi in Olmo Cenere impiallacciato, elementi **Tetris** con anta scorrevole in laccato Fango opaco e Oliva opaco con ante in Olmo Cenere impiallacciato. Elementi **interbase Liberty** sopra basi con lamiera in Peltro. **Colonne a vetro** con anta telaio in Olmo cenere impiallacciato e **colonne** con ante in laccato opaco Peltro.

Veneered Ash Olmo bases, **Tetris** elements with matt mud varnished sliding door or matt olive with veneered Ash Olmo doors. **Liberty interbase elements** over Pewter metal bases. Glass tall units with veneered Ash Olmo frame door and **tall units** with matt Pewter varnished doors.

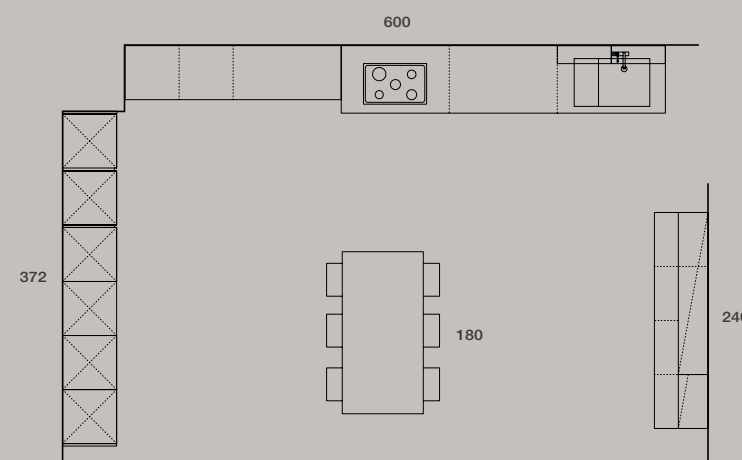







Le ante scorrono e lasciano a vista  
ciò che vogliamo sia sempre a portata di mano.  
*The doors slide and leave  
what we want to always be handy in plain sight.*





### Composizione 03

**Basi e colonne** prevalentemente in laccato Ice opaco, con inserti (elementi a giorno e cassetti) in Olmo Cenere impiallacciato. **Pensile** in Olmo Cenere impiallacciato.

**Bases and tall units** mainly in matt Ice varnish, with veneered Ash Olmo inlays (open elements and drawers) Veneered Ash Olmo **wall unit**.

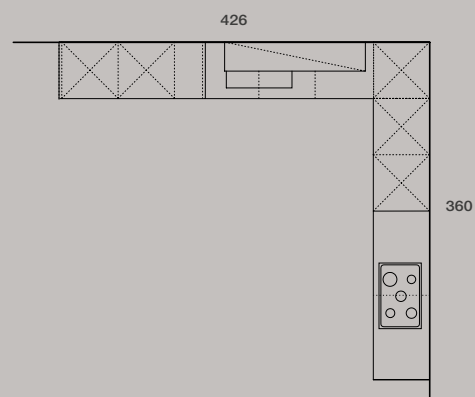

Olmo Cenere  
Ash Grey Elm

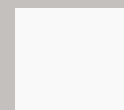

Ice opaco  
Matt Ice







### Composizione 04

Basi e colonne prevalentemente in Olmo Cenere con elementi a giorno in laccato Rosso opaco e nicchia in laccato Monolite opaco. Pensili in laccato Monolite opaco con nuovo elemento "Zeta" in laccato Rosso opaco. Isola in laccato Monolite opaco.

Bases and tall units mainly in Ash Elm with open compartment elements in matt Red and matt lacquered monolite niche. Matt lacquered monolite wall units with new "Zeta" element lacquered in matt Red. Matt lacquered Monolite kitchen island.

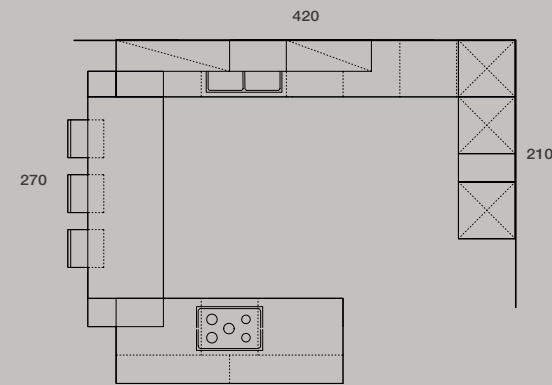

Olmo Cenere  
Ash Grey Elm



Rosso  
Red



Monolite opaco  
Matt Monolite







PARETE  
MAGNETICA



Decidi tu la posizione  
degli accessori.  
*You decide where  
to put the accessories.*



Composizione 05

Basi e colonne in laccato opaco Ice. Pensili e nicchia a giorno in Olmo impiallacciato.

Base units and tall units in matt varnished Ice.  
Veneered Olmo wall units and open niches.



Olmo  
Elm

Ice opaco  
Matt Ice

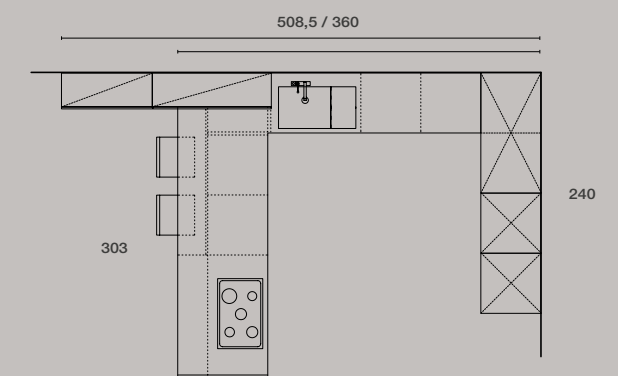





Alta tecnologia in cucina.  
*High technology in the kitchen.*



PARETE  
MAGNETICA





### Composizione 06

Isola centrale in laccato opaco Bianco Ice con inserti Tetris in Olmo Naturale impiallacciato. Colonne in Olmo Naturale impiallacciato con inserti Tetris in laccato opaco Bianco Ice.

Central Matt Ice White varnished island with veneered Natural Olmo Tetris inlays. Veneered Natural Olmo tall units with varnished matt Ice White Tetris inlays.

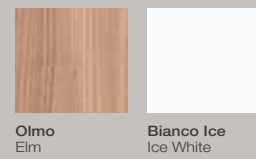
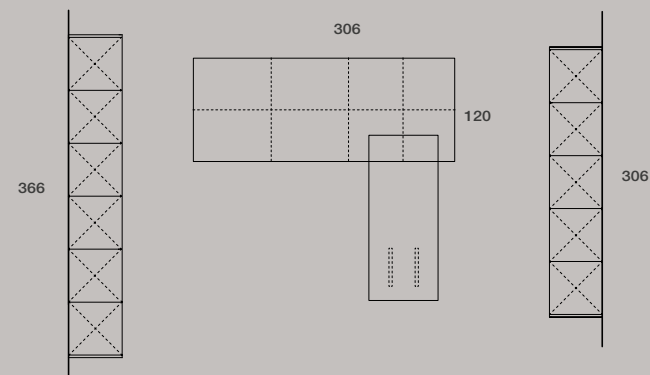



L'isola con piano Snack in essenza Olmo diventa la protagonista.  
*The island with Snack bar in Olmo steals the spotlight.*







**Composizione 07**

**Base Isola** in Olmo impiallacciato e inserti di ante ed elementi Tetris in laccato opaco Fango. **Colonne** in Olmo impiallacciato e inserti di ante ed elementi Tetris in laccato opaco Fango.

Veneered Olmo **Island Base** and inserted doors and Mud matt varnished Tetris elements. Veneered Olmo **tall units** and inserted doors and Mud matt varnished Tetris elements.

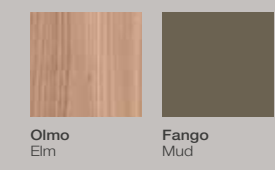
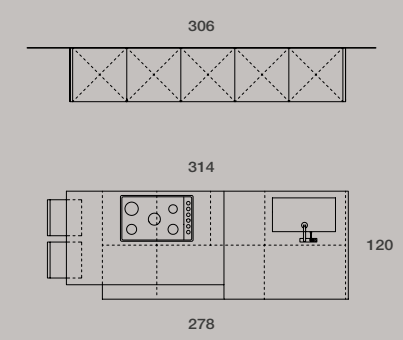



Dettagli che confermano  
uno stile ben definito.  
*The details confirm  
a well-defined style.*









Ricerca, novità, evoluzione.  
*Research, novelty, evolution.*

**Composizione 08**

**Basi** in Olmo impiallacciato. **Colonne** in Olmo impiallacciato e laccato Nuvola opaco. **Pensili** in vetro laccato Azzurro opaco.

**Bases** in Veneered Elm. **Tall units** in veneered Elm and matt Nuvola lacquered. **Wall units** in Light Blue lacquered glass.

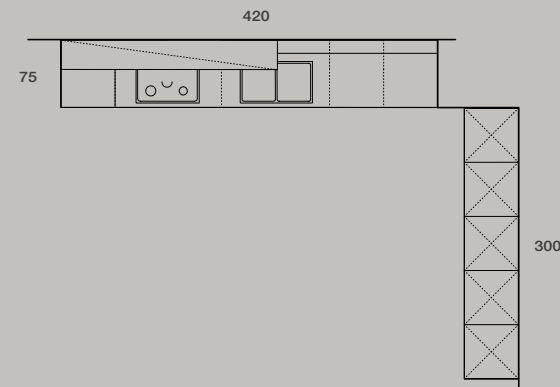

Olmo Elm      Azzurro Light Blue Filo vetro      Nuvola Cloud



Composizione \_ composition **01** pg. 2



Olmo Cenere \_ Impiallacciato  
Ash grey Elm \_ Veneered



Pomice \_ Laccato opaco  
Pumice \_ Matt lacquered



Grigio Piacenza \_ Vetro Eclettica  
Piacenza Grey \_ Eclettica Glass

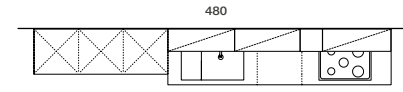

Composizione \_ composition **05** pg. 26



Olmo \_ Impiallacciato  
Elm \_ Veneered



Ice \_ Laccato opaco  
Ice \_ Matt lacquered

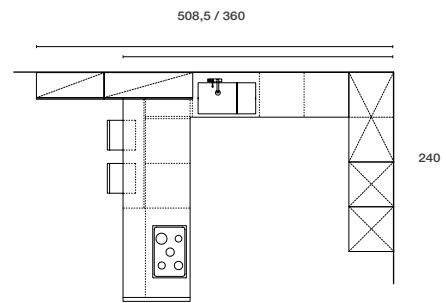

Composizione \_ composition **02** pg. 10



Olmo Cenere \_ Impiallacciato  
Ash grey Elm \_ Veneered



Oliva \_ Laccato opaco  
Olive \_ Matt lacquered



Fango \_ Laccato opaco  
Mud \_ Matt lacquered



Peltro  
Pewter

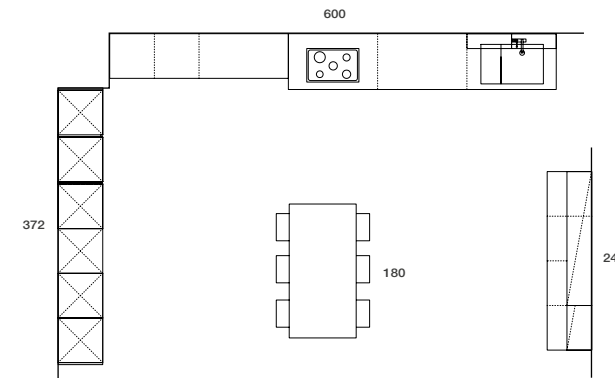

Composizione \_ composition **06** pg. 32



Olmo \_ Impiallacciato  
Elm \_ Veneered



Ice \_ Laccato opaco  
Ice \_ Matt lacquered

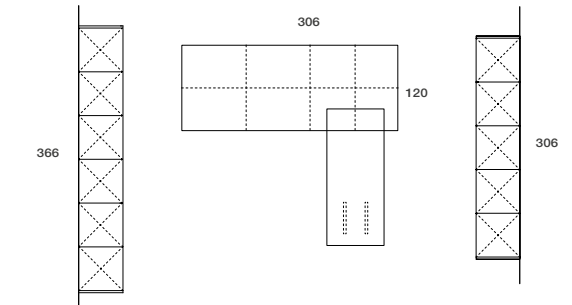

Composizione \_ composition **03** pg. 18



Olmo Cenere \_ Impiallacciato  
Ash grey Elm \_ Veneered



Ice \_ Laccato opaco  
Ice \_ Matt lacquered

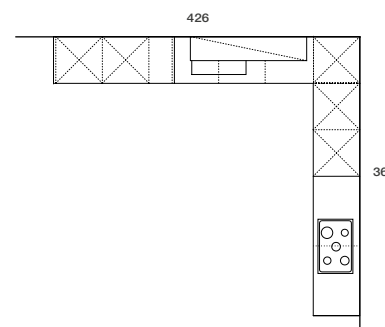

Composizione \_ composition **07** pg. 38



Olmo \_ Impiallacciato  
Elm \_ Veneered



Fango \_ Laccato opaco  
Mud \_ Matt lacquered

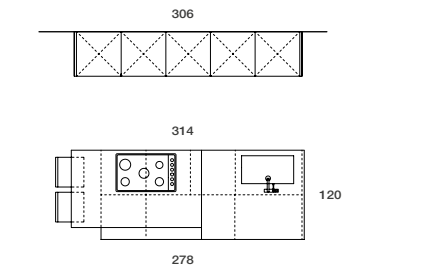

Composizione \_ composition **04** pg. 22



Olmo Cenere \_ Impiallacciato  
Ash grey Elm \_ Veneered



Rosso \_ Laccato opaco  
Red \_ Matt lacquered



Monolite \_ Laccato opaco  
Monolite \_ Matt lacquered

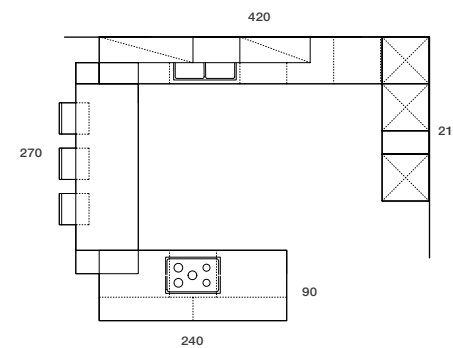

Composizione \_ composition **08** pg. 44



Olmo \_ Impiallacciato  
Elm \_ Veneered



Nuvola \_ Laccato opaco  
Cloud \_ Matt lacquered



Azzurro \_ Vetro laccato opaco  
Light Blue \_ Matt lacquered glass

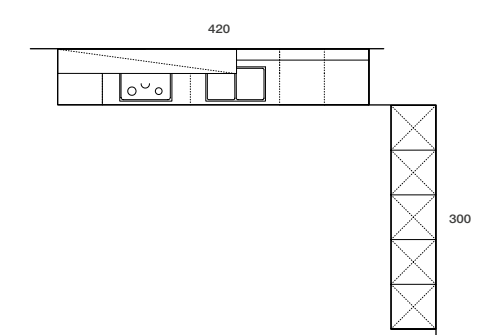

# MOOD finiture di serie\_ *standard finishes*

Spessore anta 22 mm Door thickness 22 mm

## Impiallacciati *Veneered*



**Olmo**  
Elm



**Olmo Cenere**  
Ash grey Elm

## Laccato DIRETTO opaco *Matt DIRETTO lacquer*

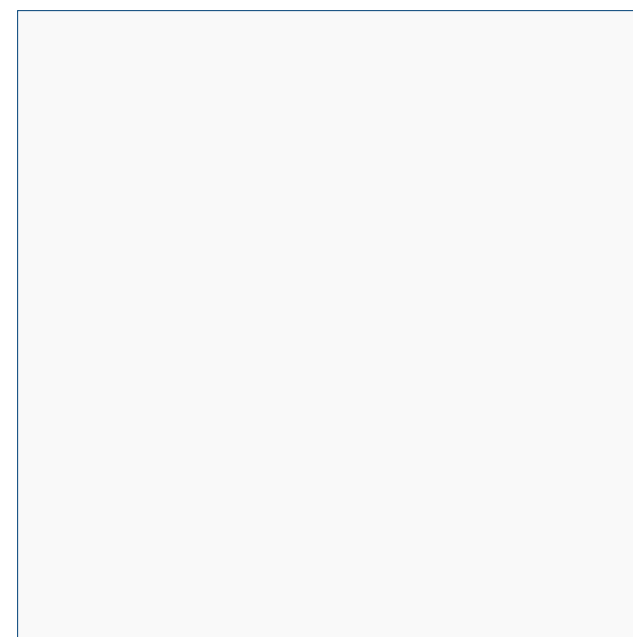

**Ice**  
Ice

# MOOD finiture su richiesta \_ *optional finishes*

Spessore anta 22 mm Door thickness 22 mm

## Laccati DIRETTI opachi *Matt DIRETTI lacquers*



**Creta**  
Clay



**Frost**  
Frost

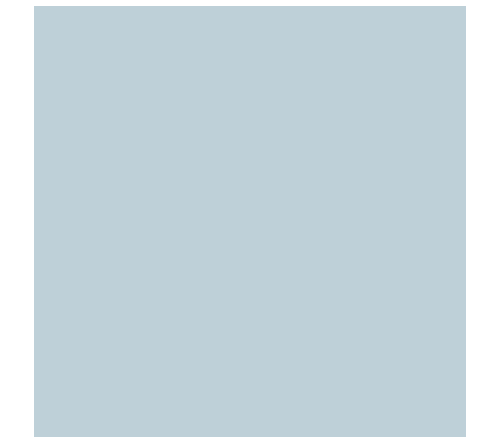

**Nuvola**  
Cloud



**Oliva**  
Olive



**Fango**  
Mud



**Pomice**  
Pumice



**Monolite**  
Monolite

**MAGGIOR  
SICUREZZA  
MAGGIOR  
STABILITÀ**  
MORE SAFETY MORE STABILITY

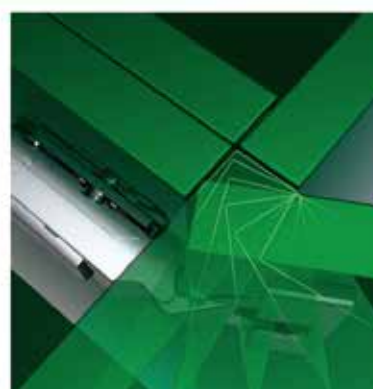

La tripla cerniera conferisce stabilità all'anta e maggior resistenza all'urto.

The triple hinge gives the door stability and greater resistance to slamming.

**Stabilità costante in ogni posizione.** Regolazione dell'altezza continua ed autobloccante.

**Durable stability in every position.** Stepless, self-locking height adjustment.

**Con o senza frenata integrata.** Stesso design per la combinazione di cerniere dotate e prive di Soft-close.

**With or without integrated damping.** Matching design for combinations of hinges with and without damping.

**Maggiore comfort attraverso l'innovazione.** Grazie al movimento della leva ottimizzato è possibile aprire le ante dei mobili in modo estremamente semplice.

**Enhanced comfort thanks to new development.** Optimised lever movement enables furniture doors to be opened with extreme ease.

**Regolazione della frenata senza utensili.** Chiusura uniforme indipendentemente dalle dimensioni e peso dell'anta.

**Tool-free damper adjustment.** Consistent closing action irrespective of door size and weight.

Design: Adriani e Rossi Edizioni  
A. D. e Grafica: Adriani e Rossi Edizioni  
Foto: Studio Indoor (Oderzo - TV)  
Fotolito: Bieffe Fotolito - VR  
Stampa: OGM  
Stampato in Italia Luglio 2014





## Stosa S.p.A.

**STAB., SEDE AMM.VA E RECAPITO POSTALE:**  
S.S. Cassia, Km. 149,5  
53040 Radicofani (SI) Italy

**GPS:**  
N 42° 53' 50,6"  
E 11° 45' 53,5"

**INFO:**  
tel. +39 0578 5711  
fax +39 0578 50088

**INFO LINE:**  
840 000 691

[www.stosa.it](http://www.stosa.it)

[stosa@stosa.it](mailto:stosa@stosa.it)



MPA03215